

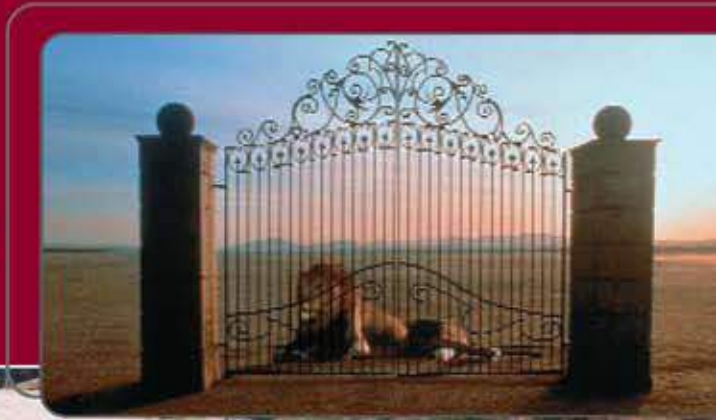

## Opening a Whole New World: FAAC Swing Gate Systems



## Model 400

The Model 400 is specifically designed for situations needing maximum versatility, such as apartment, subdivision, commercial/ industrial and residential applications. It's strength also makes the 400 ideal for large, ornate gates.

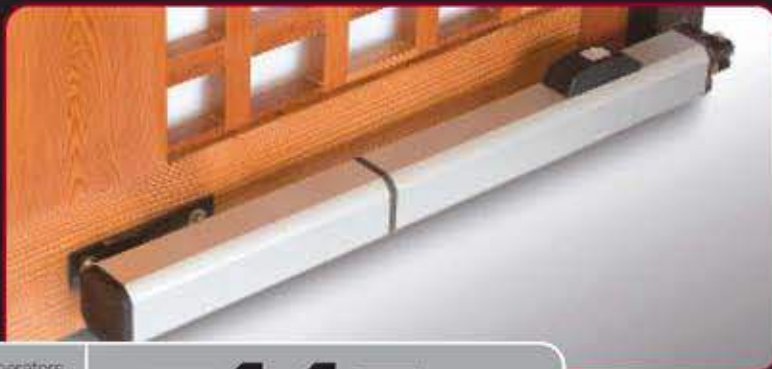

- Swing Gate Operators
- Slide Gate Operators
- Barrier Gate Operators
- Accessories

**FAAC USA**  
An ISO 9001 Certified Company

FAAC is the world's largest specialized manufacturer of gate operating equipment.

UL 325  
COMPLIANT  
CSI # 02820 -  
Gate Operators



# Model 400 Heavy Duty Swing Gate Operator

**UL 325  
COMPLIANT**  
CSI # 02820 -  
Gate Operators

The Model 400 hydraulic swing gate operator is specifically designed for situations needing maximum versatility, such as certain apartment, subdivision, commercial/industrial and residential applications. It's strength also makes the 400 an excellent choice for large, ornate gates.

Hydraulic swing gate operators are inherently safer than other types of operators because they do not have "pinch points." In addition, FAAC operators are equipped with a hydraulic bypass valve for extra anti-entrapment protection, and a manual release that allows the gate to be operated in an emergency, such as power failure. A battery back-up unit is also available.

The 400 hydraulic system can hydraulically lock your gate in your choice of the opened and/or closed positions.

Your gate system will also be set up to provide special options, including "gate-safe" and "gate-secure" configurations:

- \* Gate-safe: during power outages, a magnetic lock releases a closed gate to permit emergency access.
- \* Gate-secure: during power outages, an electric lock keeps a closed gate locked.

The versatile FAAC control panel allows for six operating modes including garage-door-like operation, and a new HOLD OPEN function.

The 400 can be mounted inside the gate and still allow the gate to open to the inside or to the outside.

NOTE: To guarantee the safety and efficiency of its equipment, FAAC strongly recommends that qualified personnel test the safety system on an annual basis, as well as maintain the overall hydraulic or mechanical system.

## Model 400 Kit includes:

- One hydraulic gate operator with mounting hardware
- One 455 D control panel
- One 14 x 16 in. weather resistant, pre-wired, UL Listed fiberglass enclosure
- One manual release key
- 115 VAC receptacle for accessories (5 amp max.)
- ON/OFF switch controlling power to control panel, accessories and plug outlet
- Large pre-wired terminals for easy wiring to control panel
- Test button
- Two warning signs



A convenient manual release is standard on all models.

UL 325 Class Descriptions & FAAC Operators			
Class	FAAC Models	Duty Cycle	Typical Use
Class 1	Residential vehicular gate operator 390, 400, 412, 415, 402, 422, 750, 760, 770, 620, 640, 885	Limited duty	•Home use •Small apartment building, up to 4 units per building, limited public access
Class 2	Commercial/General access vehicular gate operator 400, 620, 640, 885	Continuous duty	•Apartment buildings •Open public access
Class 3	Industrial/Limited access vehicular gate operator 400, 620, 640, 885	Continuous Duty	•No public access
Class 4	Restricted Access vehicular gate operator 620, 640, 885	Continuous Duty	•Prison related security

## Duty Cycle

The duty cycle achieved by a swing gate operator in terms of "operations per hour" is, in large part, a function of the installation. For example, an operator swinging a leaf through 125° will be able to complete fewer operations per hour than the same operator swinging only 90°.

The duty cycles listed below reflect performance at an ambient temperature of 72° F (22° C) and at normal voltages of 115 or 230 VAC. Changes in environmental conditions, voltage and gate condition will affect achievable duty cycle.

FAAC Operator Model	Cycles per hour
400	80
402	30
412	50
415	25
422	30
750	30
760	30



Model 455 D Control Panel shown in pre-wired hinged, lockable enclosure

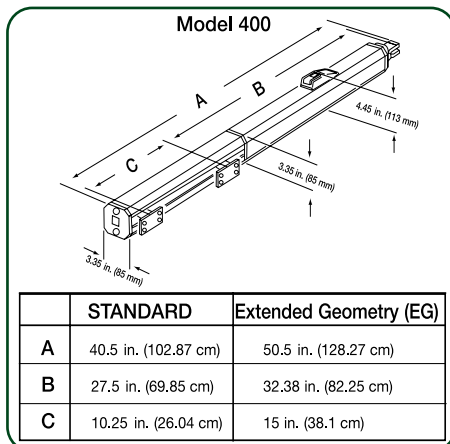

The Model 400 dimensions

## Specifications

Parameter	Model 400 Standard	Model 400 Rapid	Model 400 EG Large Leaf (SBS)	Model 400 Extended Geometry
Application	Certain apartment, subdivision, commercial, industrial, residential single leaf or bi-parting gate (vehicles only, not for pedestrian use)			
Maximum gate swing	115 degrees	115 degrees	115 degrees	125 degrees
90 degree opening time	17 seconds	12 seconds	27 seconds	18 seconds
Maximum weight per gate leaf	1300 pounds (590 kg)	900 pounds (410 kg)	2200 pounds (998 kg)	1500 pounds (650.4 kg)
Maximum length per gate leaf	16 feet (4.9 m)	12 feet (3.7 m)	22 feet (6.7 m)	18 feet (5.5 m)
Approx. operating temperature range	-33°F to 165°F (-36°C to 74°C) (For extreme temperature conditions, arctic grade fluid is available upon request)			
Hydraulic locking	Available in opened and/or closed positions	Available in opened and/or closed positions	Not available	Available in in opened and/or closed positions
Voltage	115 VAC (2.5 A) or 230 VAC (1.5 A)			
Operator weight	29 pounds (13.2 kg)	29 pounds (13.2 kg)	34 pounds (15.4 kg)	34 pounds (15.4 kg)
Oil Quantity	2.3 quart (2.2 l)	2.3 quart (2.2 l)	2.9 quart (2.7 l)	2.9 quart (2.7 l)

Note: Operator specifications are approximate. Environmental factors can change the performance of the operator. Your installer will advise you which model of operator will work best for your site and application.

## Speed and leaf length

Some thought should be given to the speed at which the gate will travel. The longer the gate leaf, the faster the traveling edge must move to clear an area in a given amount of time.

A speed of 40 feet/minute (12.2 meters/minute) is a "bench mark" velocity. It permits efficient operation while limiting the energy in the moving gate leaf. The lower the energy, the less chance of damage to property or injury to people in the event of accidental contact with the moving gate.

Examples illustrating the relationship between operator speed, gate leaf length, and the velocity of the leaf's traveling edge

Speed options available (time needed to swing a gate 90°)	EXAMPLE: Velocity of the traveling edge of an 8 ft (2.4 m) leaf [in feet/m and (meters/m)]	Longest leaf which can be used if the velocity of the traveling edge is not to exceed 40 fpm (12.2 mpm)
6 sec.	126 fpm (38 mpm)	2.5 ft (0.8 m)
12 sec.	63 fpm (19 mpm)	5 ft (1.5 m)
15 sec.	50 fpm (15 mpm)	6 ft (1.9 m)
17 sec.	44 fpm (14 mpm)	7.5 ft (2.3 m)
23 sec.	33 fpm (10 mpm)	10 ft (3 m)

# Model 400 Mounting Geometry

Sometimes the mounting measurements will result in a flush mounting. Other applications require a column to be notched in order to accommodate the correct mounting geometry.

Note: If, in your installation, notching a column is not practical, other solutions are available:

- Install operators using an outward swing.
- Upgrade to an operator with more mounting flexibility.
- Use a Pantograph.
- Use an in-ground operator.

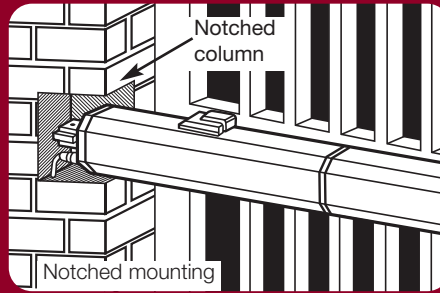
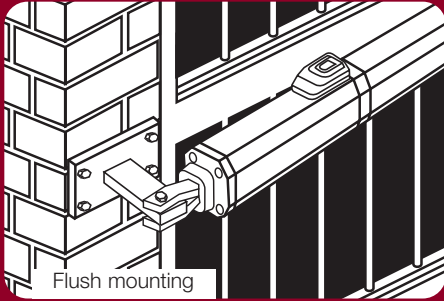

Decisions regarding mounting geometry apply to gate mounted operators: Models 400, 402, 422 and 412 .

As shown in the diagrams below, the operators must be mounted at an angle to the gate. Correct mounting geometry assures that the desired degrees of swing are achieved, that the gate speed is correct, and that the operator and gate will operate properly and have a long life.

OUTWARD-swinging 400 operators, top view.

### Dimensions

- A 5 in. (13 cm)
- B 5 in. (13 cm)
- C 27.56 in. (70 cm)
- D no limit
- E MUST be less than A

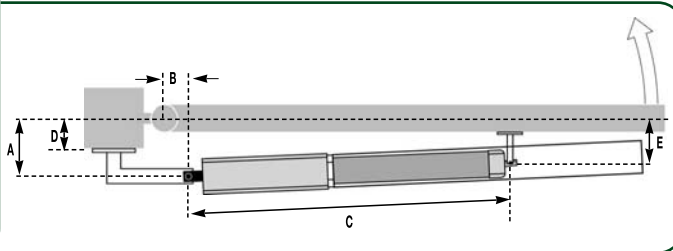

INWARD-swinging 400 operators, top view

Model		90° Swing	115° Swing	125° Swing
400 Standard, high speed and slow speed models	A	5 in. (13 cm)	4 in. (10 cm)	NA
	B	5 in. (13 cm)	4.75 in. (12 cm)	NA
	C	38.19 in. (97 cm)	38.19 in. (97 cm)	NA
	D	max. 3 in. (8 cm)	max. 2 in. (5 cm)	NA
400 EG (Extended Geometry)	A	7.88 in. (20 cm)* or 11.5 in. (29 cm)**	5.75 in. (14.6 cm)**	4.75 in. (12 cm)
	B	7.5 in. (19 cm)* or 3 in. (7.5 cm)**	7 in. (17.8 cm)	6.63 in. (17 cm)
	C	47.63 in. (121 cm)	47.5 in. (120 cm)	47.5 in. (120 cm)
	D	up to 5.25 in. (14 cm)* or 10 in. (25.5 cm)**	up to 3.5 in. (8.9 cm)**	up to 2.88 in. (7 cm)

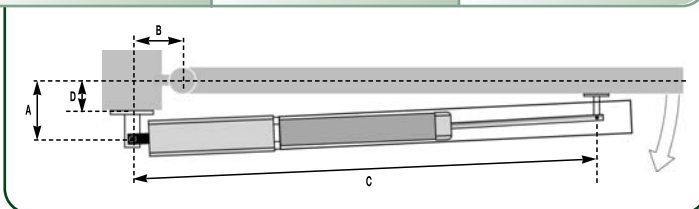

\* For A, B, and D, if you choose one of these values with one asterisk, then you must choose the other values with one asterisk. \*\* For A, B, and D, if you choose one of these values with two asterisk, then you must choose the other values with two asterisks.

## How many degrees of swing are required?

- One FAAC gate operator (Model 750) can swing a gate up to 180°.
- All models of FAAC operators can swing a gate at least 90°.
- Openings which require swings greater than 90° will need certain FAAC operator models.
- The swing of an operator applies equally to inward or outward swinging gates.

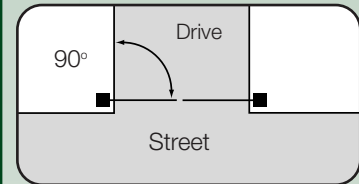

All FAAC operators:  
Models 412, 402, 422, 400,  
750, 760

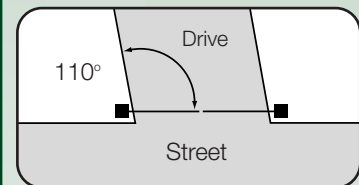

Models 412, 400, 750, 760.

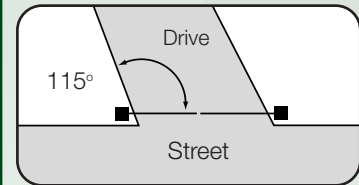

Models 400, 750, 760.

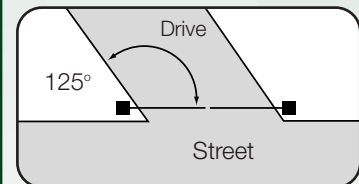

Models 400 EG (extended geometry),  
750, 760.

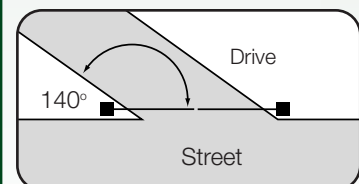

Models 750 (up to 180°),  
760 (up to 148° with "soft stop")



## Use FAAC to build a complete gate system

Model 455 D pre-wired control panel



Some access control options to open a gate



Telephone entry systems

Electric and magnetic locks



Battery back-up



Photobeams



Photobeams and aluminized photobeam stands



Loops and photobeam safety

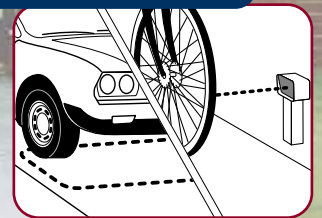

Model 400 heavy duty hydraulic swing gate operator



## All Model 400 kits include a Model 455 D control panel.

### features include:

- One 455 D operates single leaf or bi-parting gates
- Provides opening and closing "slow down, soft stop" convenience
- Easy interconnection of loop detectors, photobeams, etc. to reverse a gate if an obstacle is sensed
- Easy interconnection of actuating devices like remote control radios, key pads and telephone entry systems
- On board programming via push button
- Panel also allows for the use of FAAC Gate Coders, for "real time" tracking of gate position
- Selectable logics:
  - A (automatic): signal to open, gate closes automatically after selected timed pause
  - S (security): similar to A logic, useful in reducing tailgating
  - E (semi-automatic): garage door-like operation; signal to open, signal to close
  - EP (semi-automatic): similar to E logic, but second signal stops gate, third signal reverses gate
  - B (manned, pulsed): designed for guard station use, requires 3-button switch (pulsed) to open, close and stop gate
  - C (manned, constant): similar to B logic, but 3-button switch requires constant pressure on each button

## Positive gate stops

Positive gate stops, which limit the travel of each gate leaf, are required in the opened and closed positions for all gate systems using FAAC operators.

FAAC offers three innovative gate stops for different applications. The Model 84 heavy duty, adjustable stop is designed specifically for the Model 400 operator and features four tie rods for added stability.

For aesthetic purposes, the Model 84 is totally concealed under the operator cover.



### Features include:

- Stainless steel construction
- Mounts with existing FAAC hardware and does not require additional attachment parts
- Accommodates inward or outward swing
- Maximum degrees of swing:
  - 115 degrees for Model 400 standard
  - 125 degrees for Model 400 long





FAAC's U.S. headquarters in Cheyenne, Wyoming



Founded in 1965, FAAC has risen to become the world's largest specialized manufacturer of automated operators for swing, slide and barrier gate systems.

International company headquarters, research & development and primary production facilities are located in Bologna, Italy. Dublin, Ireland is the site of FAAC's research, design and production facility for electronic controls including photocells, radio controls and code opening systems.

HEADQUARTERS  
Bologna, Italy

RESEARCH & DEVELOPMENT  
Bologna, Italy  
Dublin, Ireland

PRODUCTION FACILITIES  
Bologna, Italy

SUBSIDIARY OFFICES  
Wals-Siezenheim, Austria  
Corbas-Lyon, France  
Freilassing, Germany  
Alcobendas-Madrid, Spain  
Illnau, Switzerland  
Basingstoke, Hampshire, U.K.  
Cheyenne, Wyoming, U.S.A.



FAAC International, Inc.  
303 Lexington Avenue  
Cheyenne, WY 82007  
1-800-221-8278  
Fax: (307) 632-8148  
Web: [www.faacusa.com](http://www.faacusa.com)

