

APT (LOGIC 5.0) APARTMENT TROLLEY OPERATOR

SECTION 08 71 13

KEY FEATURES

STANDARD APPLICATION	Recommended for standard-lift sectional overhead doors in higher duty-cycle commercial applications; ideal for parking garages
RATED DUTY CYCLE	Standard-duty: Up to 25 cycles/hour and up to 125 cycles/day when distributed over a minimum of 8 hours (using continuous-rated motor)
OPERATOR SPEED	6-7 Inches per second
LIMIT SETTINGS	Mechanical
EMERGENCY DISCONNECT FOR MANUAL OPERATION	Emergency release rope and handle
EMERGENCY DISCONNECT WITH AUTO-RECONNECT	Automatically reconnects trolley to trolley chain following manual operation for convenience
PROGRAMMING	Control function selector dial/tactile buttons
CIRCUIT BOARD	Solid-state Logic 5.0 circuit board
TIMER-TO-CLOSE	Programmable in 1 second and 15 second increments up to 68 minutes, standard
CLUTCH	Standard adjustable friction clutch
MID-STOP	Programmable
RUN TIME PROTECTION	Maximum run timer
MOTOR REVERSE ACTION PROTECTION	Delay-on-reverse circuit
MOTOR OPERATOR WALL CONTROL	3-Button Control Station with Maintenance Alert System (MAS)
TROLLEY TRACK	Dual L-rail trolley track
PUSH BUTTON STATION	3-Push button station (Open/Close/Stop)



SPECIFICATIONS

RADIO RECEIVER	LiftMaster Security+ 2.0® and backwards compatible to Security+ 315 or 390 MHz residential garage openers
VOLTAGE CONNECTIONS	Single-phase: 115V/230V dual voltage
CONTROL CIRCUIT	5VDC NEC class 2
DRIVE REDUCTION	Belt/chain & pulley; first-stage heavy-duty 5L V-belt; second and third stages #41 chain; #48 output chain on trolley
BEARINGS/BUSHINGS	Industrial ball bearings on output and first reduction shafts; bearings on second reduction shaft
BRAKE	Solenoid standard
CONSTRUCTION	NEMA 1 type electrical box; heavy-duty 11-gauge steel frame with durable powder coat finish; all reduction sprockets drilled and pinned to shafts
TROLLEY ROLLER CHAIN	#48 standard
WARRANTY	2 years

INSTALLATION FEATURES

MAXIMUM DOOR HEIGHT	24 feet standard with additional capability*
MAXIMUM DOOR WIDTH	22 feet standard with additional capability*
MAXIMUM ALLOWABLE SQUARE FOOTAGE	250 square feet
INTERNET CONNECTIVITY	myQ® Technology enables remote monitoring and control of the commercial door via a smartphone, tablet, or computer**

This commercial door operator must feature constant pressure to close or be equipped with an external monitored entrapment protection device. Use only LiftMaster monitored entrapment protection devices itemized on the accessory page of the operators installation manual to meet UL 325 requirements.

* Contact us at Specs@LiftMaster.com for additional capabilities.

**LiftMaster Internet Gateway and myQ app required.

DATA SHEET
APT (LOGIC 5.0) APARTMENT TROLLEY OPERATOR

LiftMaster

APT (LOGIC 5.0) APARTMENT TROLLEY OPERATOR

SECTION 08 71 13

DIMENSIONS

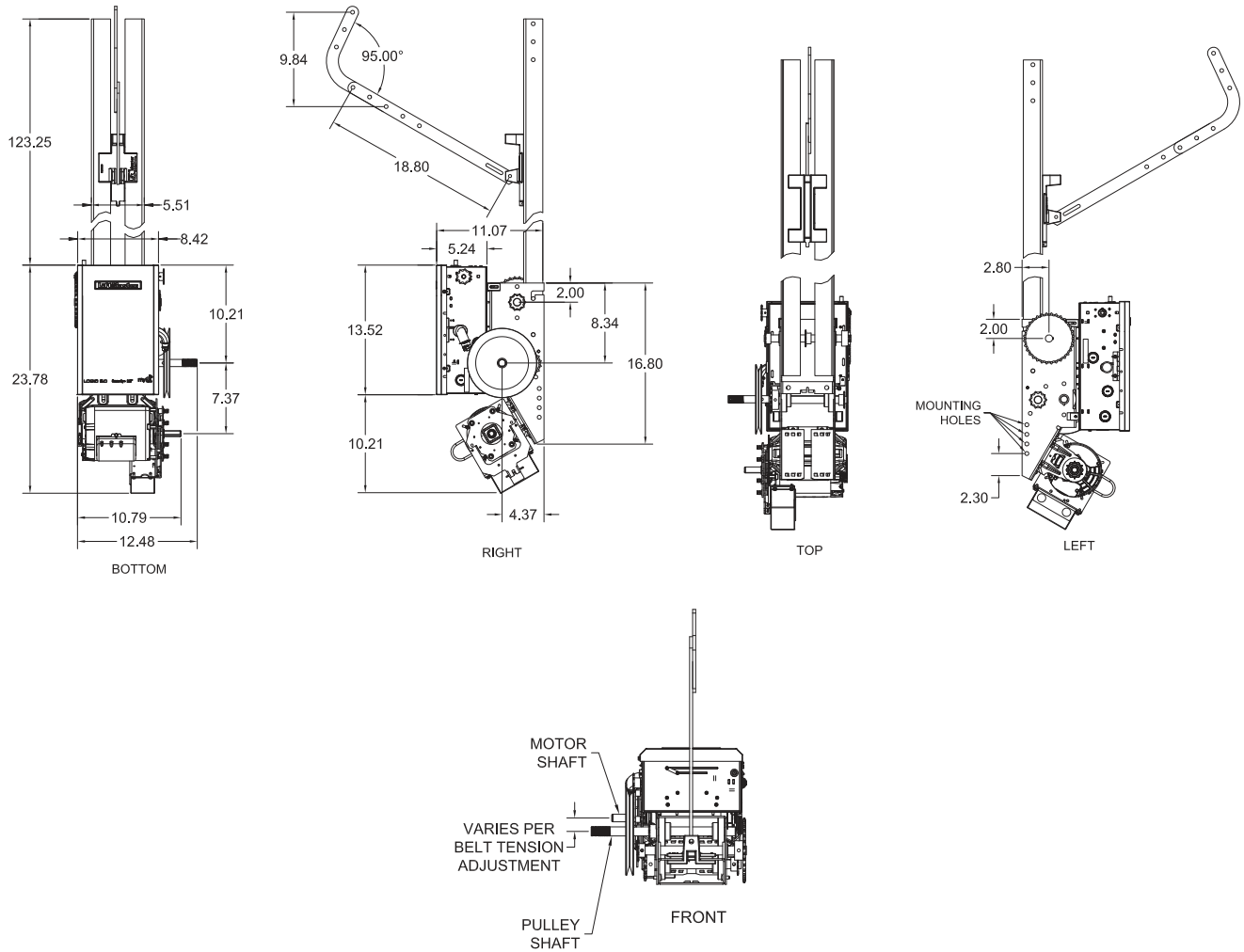

CAPACITY

MAXIMUM DOOR AREA (SQ. FT.)				
STANDARD SECTIONAL	24 ga. Steel	20 ga. Steel	16 ga. Steel	—
	Aluminum Doors	Wood Doors	—	—
	Fiberglass Doors	24 ga. Steel Insulated	20 ga. Steel Insulated	16 ga. Steel Insulated
HP 1/2	250	225	150	100

DOOR SIZE SELECTION GUIDE		
HP	Maximum Door Weight (lbs.)	Maximum Door Area (sq. ft.)
1/2	1300	260
3/4	1850	340
1	2400	480

On steel insulated doors, a 24-gauge back panel is assumed.
Recommended max duty cycles: For applications requiring over 100 cycles per day.